

Conical Rounder

Konik1



The **conical rounder** is ideal for rounding both soft and medium doughs. Rounding is achieved by a rotating cone which rotates the dough along concave channels to produce roundly shaped dough.

The machine can be equipped with a hot/cold air blowing system, so wet dough can also be processed. The machine is equipped with an automatic flour duster which is easy removed for cleaning. The channels are Teflon coated to prevent the dough from sticking.

ADVANTAGES

- Channels and cone are Teflon coated to prevent dough sticking
- Hot or cold air blowing is available
- Stainless steel plating
- Construction of machine ensures durability of machine with minimal maintenance
- Easy cleaning
- Easily removable stainless steel flour duster
- Possibility to adjust the position of the control panel plate
- Wheels with brakes

Conical Rounder Konik1

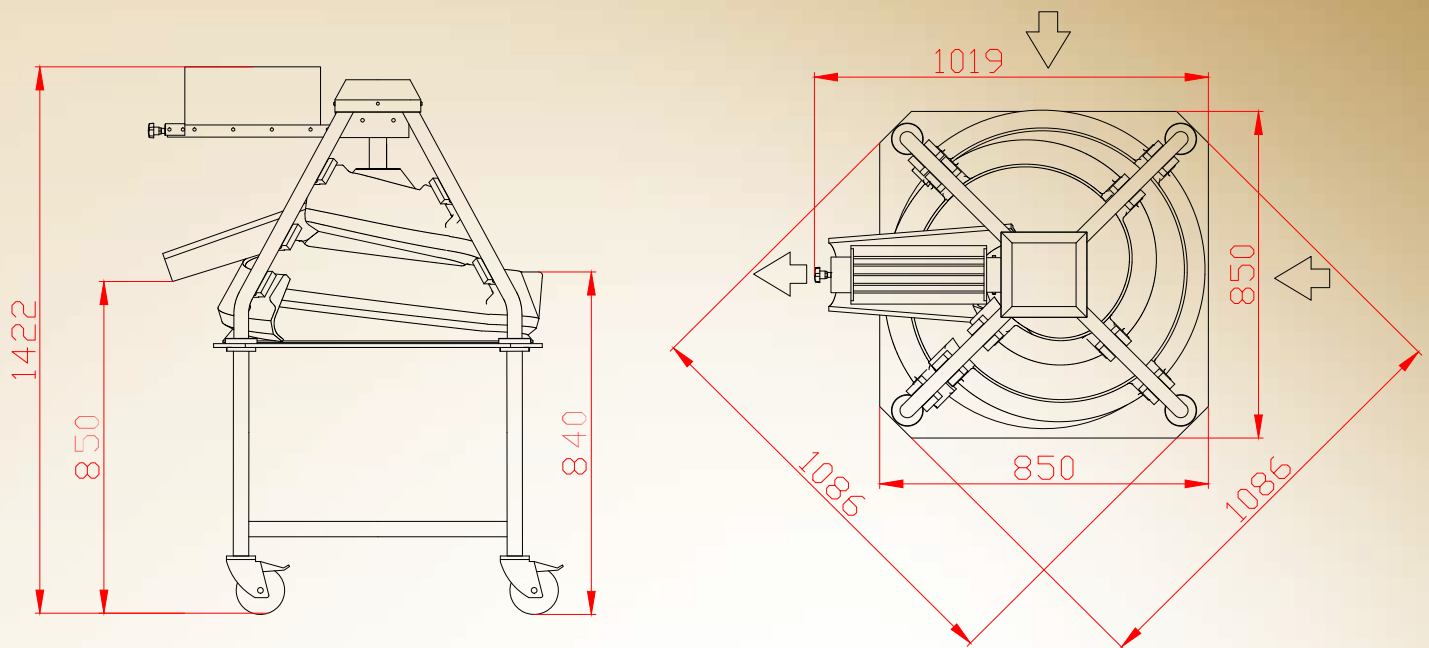

TECHINCAL DATA

Machine capacity (depending on weight and quality of dough)	2400 pcs/h
Channel length	3750 mm
Weight of shaped dough pieces	
Model: I	100 - 500 g
Model: I - II	200 - 1200 g
Model: II	400 - 1800 g
Installed power (with blowing)	0.75 kW (3.15 kW)
Weight (with blowing)	245 kg (260 kg)

We reserve the right to make changes.